



On target
to revolutionise
your throughput



INFINITE POSSIBILITIES.®





INFINITE POSSIBILITIES.®

What if you could have the optimum tool, with the marginal cost increase more than covered by improved production throughput and efficiency? With Quickgrind, you can. Welcome to a world of Infinite Possibilities.®

At Quickgrind we do not limit ourselves to standard ranges, and we do not limit you to tools we happen to have in stock and want to sell you. Instead, our mission is to provide you with solution-based tooling, to give you the right tool, for the right job, at the right price.

Eliminator barrel tools can be designed specifically for your application and are available in virtually any size, diameter, radius, neck relief, coating or reach. Through-coolant and other options are also available.

End the compromise of standard tooling. Contact our team today to discuss your applications, aims and requirements. There are no limits, only Infinite Possibilities.®

Call +44 (0) 1684 294090
or visit quickgrind.com

Ordering is as easy as one, two, three

1. Choose your shank spec

- Length • Diameter • Tolerance
- DIN or other shank standards

2. Choose your neck spec

- Length • Diameter

3. Choose your head spec

- Full selection process assistance • Diameter
- Tolerance • Flute radius/length
- Ballnose diameter
- Conical, tangential, form F, lens
- Number of flutes • Helix angle
- Radial/axial through-coolant
- MX, XRed or TX coating
- Chip breakers

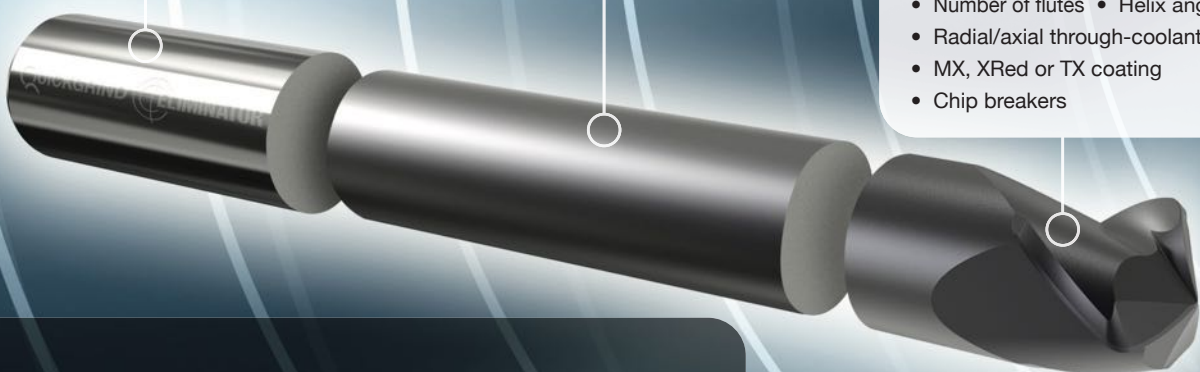

That's it. No catalogues to trawl through, no complicated product codes, no lengthy tables, just tell us what you need for your job and we will make it for you. Even specials can be designed, proved and delivered in days, at a cost you could recoup on your first job. That's Infinite Possibilities.®

**Remember, just ask
we will make it for you**

Transforming

finishing strategies

Quickgrind's Eliminator barrel tools are revolutionising finishing and semi-finishing strategies on a wide range of components in motor racing to mould and die, and aerospace to medical, including turbine blades and blisks.

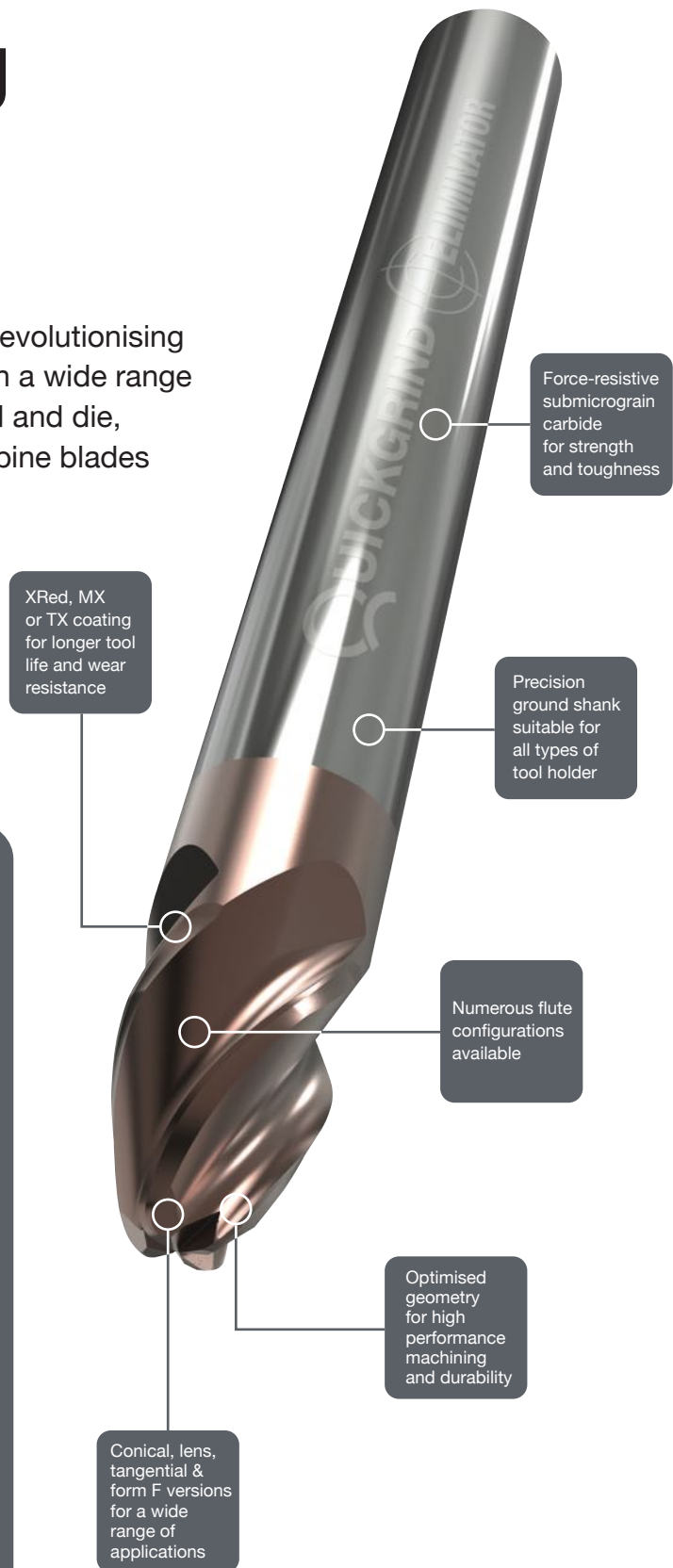

Applications

- Replaces scanning with ballnose and corner radius endmills
- Highly efficient finishing and semi-finishing
- Profiling, flanks and steep walls
- Mill faces and blends with one tool
- Machining steep or flat planes
- Faces with minimal curvature

Benefits

- Up to 90% cycle time reduction achievable
- Increased ap (step down) – greatly reduced machining time
- Smaller cusp (scallop) height
- Tool path distance greatly reduced – better for your machine
- Two-in-one tool – side cutting and ballnose cutting
- High Ra finish
- Reduced effects of thermal deformation (heat transfer)
- Long tool life
- Suitable for sharpening and recoating multiple times with our QuickEdge programme

Innovating for unlimited potential

Eliminator is an exciting range of barrel tools that takes the arc segment of a circle to form the radius of the flute, enabling improved step down strategies when compared to ballnose endmills and reducing cycle times by up to 90%.

Until now the conventional way to produce a required finish was to use a ballnose. This limits the step down, generally calculated as $ap = 0.02 \times D1$. For example, a 10.00mm diameter ballnose can achieve an ap of 0.20mm.

Increasing the step down would normally require a much larger diameter cutter which would not be practical – the Eliminator barrel tool does not have such limitations. The contact area is much greater because the flute radius is adapted from the segment of a much larger circle. If you wanted to increase the step down from 0.2mm to 5.0mm you would need a 250mm diameter ballnose. However, by taking a segment of a 250mm diameter circle to form the flute of your tool, and applying this to any diameter tool, you can achieve a 5.00mm step down.

Available in conical, lens, tangential and form F versions with geometries, number of flutes and dimensions to suit your individual applications, Eliminator significantly reduces finishing cycle times on deep pockets, shallow pockets with small radii, hard to reach faces, radial and tangential faces, gear cutting, blisks, vanes and moulds which would all normally require a ballnose.

The full Eliminator range is available to you now, with custom-made tools on a short delivery.

**Start your cycle time
and finishing revolution today.
Call +44 (0) 1684 294090
or visit quickgrind.com**

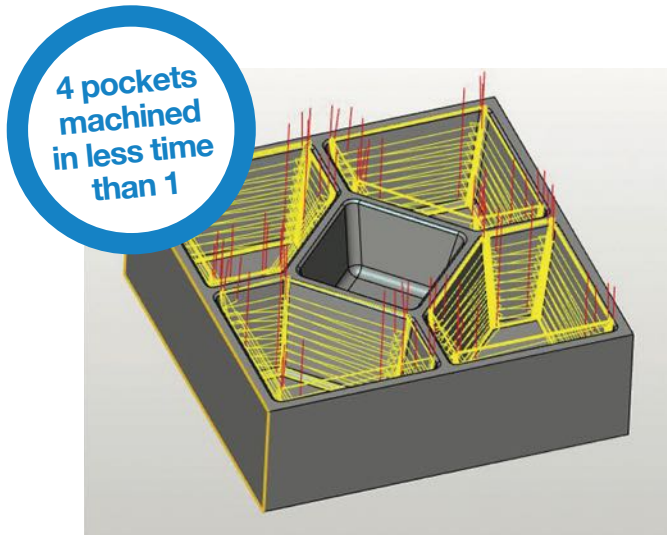

Eliminator

12mm Ø R3 conical barrel tool with 250mm flute radius

Spindle speed – 7,958 rpm

Feedrate – 2,984 mm/min

2 minutes 11 seconds for each pocket

4 pockets machined in 8 minutes 46 seconds

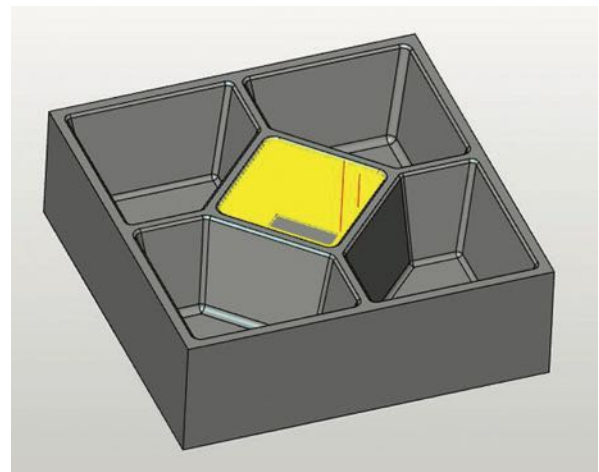

Ballnose

6mm Ø ballnose

Spindle speed – 10,610 rpm

Feedrate – 2,122 mm/min

1 x middle pocket only

1 pocket machined in 9 minutes 24 seconds

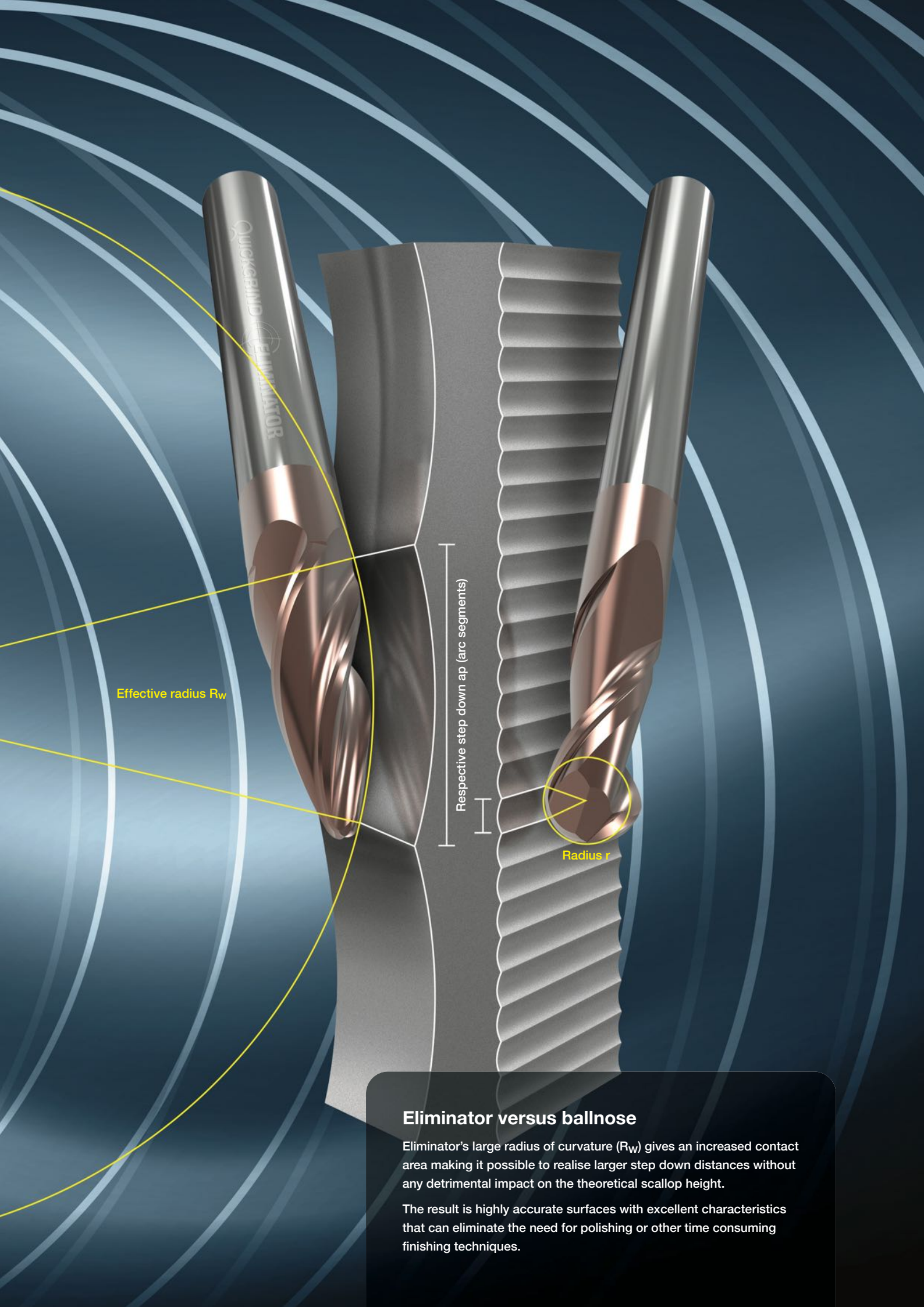

Effective radius R_w

Respective step down a_p (arc segments)

Radius r

Eliminator versus ballnose

Eliminator's large radius of curvature (R_w) gives an increased contact area making it possible to realise larger step down distances without any detrimental impact on the theoretical scallop height.

The result is highly accurate surfaces with excellent characteristics that can eliminate the need for polishing or other time consuming finishing techniques.

Finishing

in record time

Use of Quickgrind's Eliminator barrel tools demands a suitable CAM solution that fully exploits the potential of their geometry. Combined with our QuickCam programming and machining strategies, your profitability and competitiveness will be transformed.

QuickCam promises performance enhancing strategies to suit the parts you make and the machines you use, initially via an on-site visit to help us better understand your requirements. The service offers the very latest cutting-edge carbide tools and by using *hyperMILL*[®] MAXX machining cycles, as well as those provided by other CAM providers, we can offer a very competitive and professional service by ensuring that we always use the most up-to-date machining tool paths. We are an application partner with OPEN MIND and work with many other CAM providers.

You may only require a section of code to aid your machining processes. In this case we will provide an NC programme in the format of your choice which can simply be inserted into your existing programme either by adding it to the original or by use of a sub-programme.

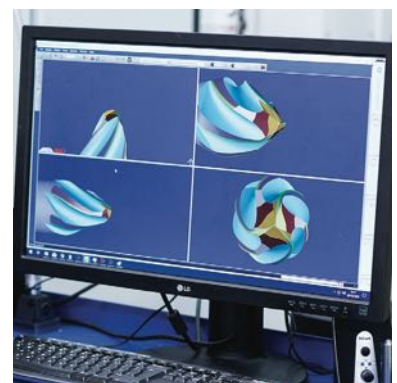

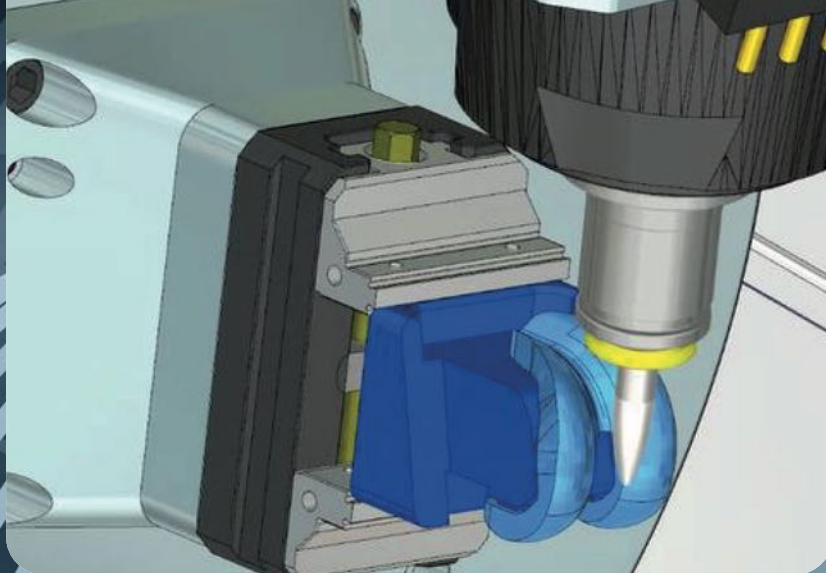

Condyle surface target
Ra value 0.2
(0.08µm)

Free-form
condyle
surfaces

Multi-axis
machining
strategies

Medical grade
321 titanium
stabilised
stainless steel

Cycle
time down
60%

Comparative performance

	Eliminator R80 4 flute barrel tool	R4 2 flute ballnose end mill
Vc	103 m/min	68 m/min
Step down	0.58mm	0.103mm
Cycle time	19 mins	47 mins

Force-resistive submicrograin carbide

Quickgrind's substrate offers the perfect mix of durability, hardness and performance. Precision shanks ensure high concentricity for precision toolholders, whilst the structure provides a durable cutting edge.

Your choice of coatings

Coatings are available for a wide range of materials and applications, for both wet and dry machining. The coatings' outstanding adhesion delivers extended tool life and improves performance, with excellent reliability resulting from high mechanical and thermal resistance.

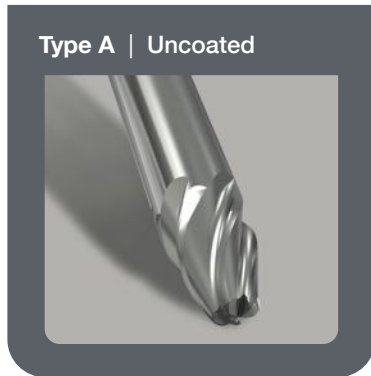

Non-ferrous N	
Aluminium 6061/6082	Die-cast aluminium 10% Si



Steels P	
Low alloy 1000/1100/1300	Medium alloy 200/252/300
Tool steels H13/P20/D2	High strength 420/5120
Cast iron K	
Grey cast iron	SG iron
Hardened materials H	
Hardened steels 45-55 Hrc	

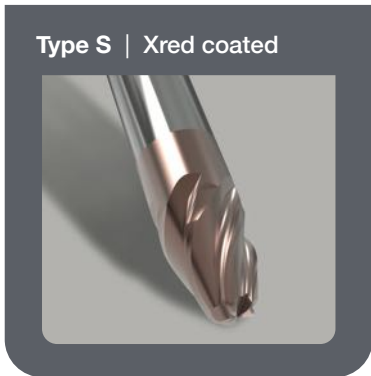

Stainless M	
Precipitation 13-8/15-5 17-4PH	Austenitic 303/304/316L
Martensitic 403/410/416	
High temp alloys S	
Inconel Hastelloy Incoloy	Titanium alloys Ti6AL4V Ti5Al-5V-5Mo

A selection of available geometries



Conical 2 flute
For aluminium

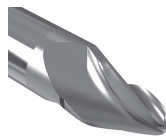

Conical 3 flute
For aluminium



Conical 5 flute
For steels & super alloys

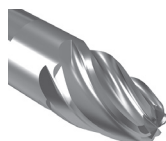

Conical 6 flute
For steels & super alloys



Conical 10 flute
For steels & super alloys

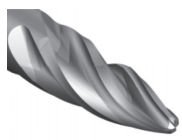

Tangential
For ease of access



Form F
For flat surfaces

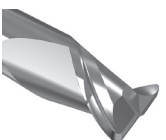

Lens
For convex & concave surfaces

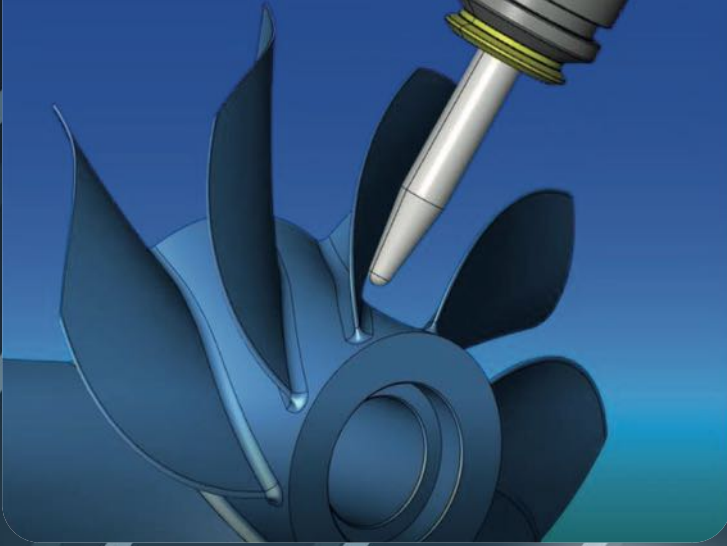

Aluminium alloy

Vc 850 m/min



3mm
step down*

80% cycle
time reduction
compared to
ballnose

Cycle
time down
80%

Key benefits

- Far better cutting conditions for the tool
- Cutting on the flank rather than the ball end
- Cutting speed maintained over feature
- Longer tool life

Adding value

to your tooling investment

Eliminator barrel tools are suitable for remanufacture. Our unique QuickEdge process can give you up to nine times extra usage out of your tooling, and with material (and environmental) costs increasing, the benefits of remanufacture are clear.

- Tools controlled by size, number of reissues and remanufactures
- Extremely attractive price and performance over the life of the tool
- Reduces the need for virgin raw material, a limited resource

Remanufacture doesn't mean compromising on quality. It has always been our policy to produce tools of such high quality that they can be used more than once. Which means that even after nine remanufactures you will continue to enjoy new tool performance, and a clear conscience.

Ask
about our
introductory
offer today

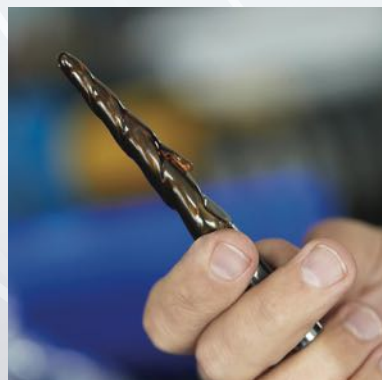
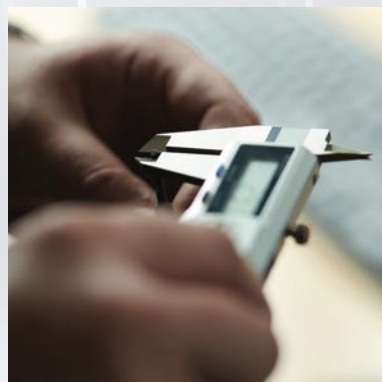

24/7 control

of your tooling inventory

Is your tooling inventory reduced to a minimum? Is it secure?
Are your re-stocking orders generated automatically and on time?
Do you want to reduce your tool purchase administration costs?

Quickgrind's robust, proven tool vending solutions are the answer to all these issues and more. Once we have audited your tooling requirements and consumption levels, we will supply you with a fully stocked machine (our machines can hold from 528 to 1,680+ individual tools). Usage and stock levels are then automatically monitored and replacement tools sent before your stock runs out.

And because your tooling inventory and usage levels are pre-determined, you regain complete control of your purchase administration time and costs, to as little as one purchase order and one invoice per month.

Save time and money. Take control of your tooling with a vending solution from Quickgrind.

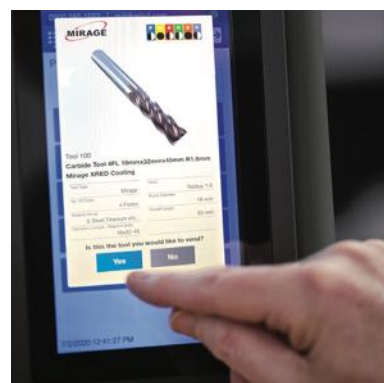

Benefits

- 24/7 secure access
- Allows minimum stock holding
- Automatic re-ordering
- User-friendly operation
- Tailor access to specific users and times
- Easy access to stock information and statistics
- Audit your tooling stock at the push of a button
- Suitable for new and remanufactured tools
- Stocks a wide range of tools types and sizes, and for high or low stock turnover
- Reduces purchase administration costs

Improving your machining performance

Quickgrind's state-of-the-art Technical Centre offers a comfortable and technologically advanced environment to discuss all of your cutting tool requirements, challenges and ambitions.

Our experts will work with you to conduct trials whilst generating and running tool paths and machining strategies. Our investment in the centre enables us to demonstrate what is possible with our ground-breaking tooling and tool management solutions.

The centre is fully equipped with a seminar theatre and training room, meeting rooms and machining centres. Visitors can take a guided tour of our production facility, undergo technical training and discuss their specific requirements.



Call us today to arrange your visit



Quickgrind Limited | Unit 5701 Shannon Place | Shannon Way
Tewkesbury | Gloucestershire | GL20 8SL | United Kingdom
t +44 (0) 1684 294090 | e contact@quickgrind.com | w quickgrind.com

@quickgrind