

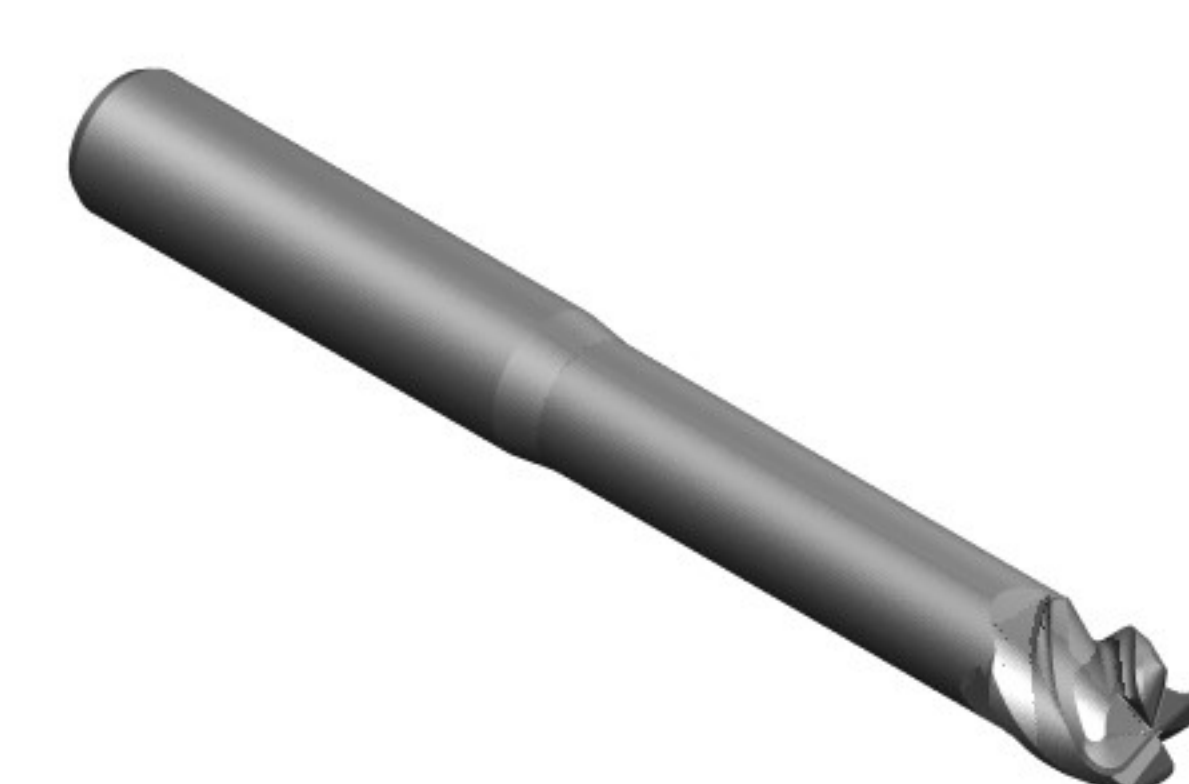

**TOOL GEOMETRY DATA**

D	Diameter (End)	10 mm
Ds	Diameter (Shank)	10 mm
L	Length Of Cutting Edge.	10 mm
Ls	Length to Shank.	60 mm
Dn	Shank Neck Diameter.	9 mm
Lo	Overall Length.(Blank)	100 mm
T	Taper Angle (OD).	
R	Corner Radius	2 mm
N	Number Of Flutes.	4
P	Primary Relief (OD).	
Rd	Raised Depth (OD).	
Rw	Raised Land (OD).	
Sw	Secondary Land Width.	
F	Flute Depth	
Ra	Flute Rake. (Hook )	
Ty	Relief style.	
Pe	Primary Relief (End).	
Pl	Primary Land (End).	
Se	Secondary Relief (End).	
Da	Dish Angle (End).	
Ax	Axial Gash Angle.	
h	Gash Pad Width.	
H	Over Centre Length.	
Y	Gash Web Thickness.	
Hx	Helix Angle	
Ga	Gash Angle (L/S)	
Ro	Permissable Runout.	
Rl	Raised Land Length	

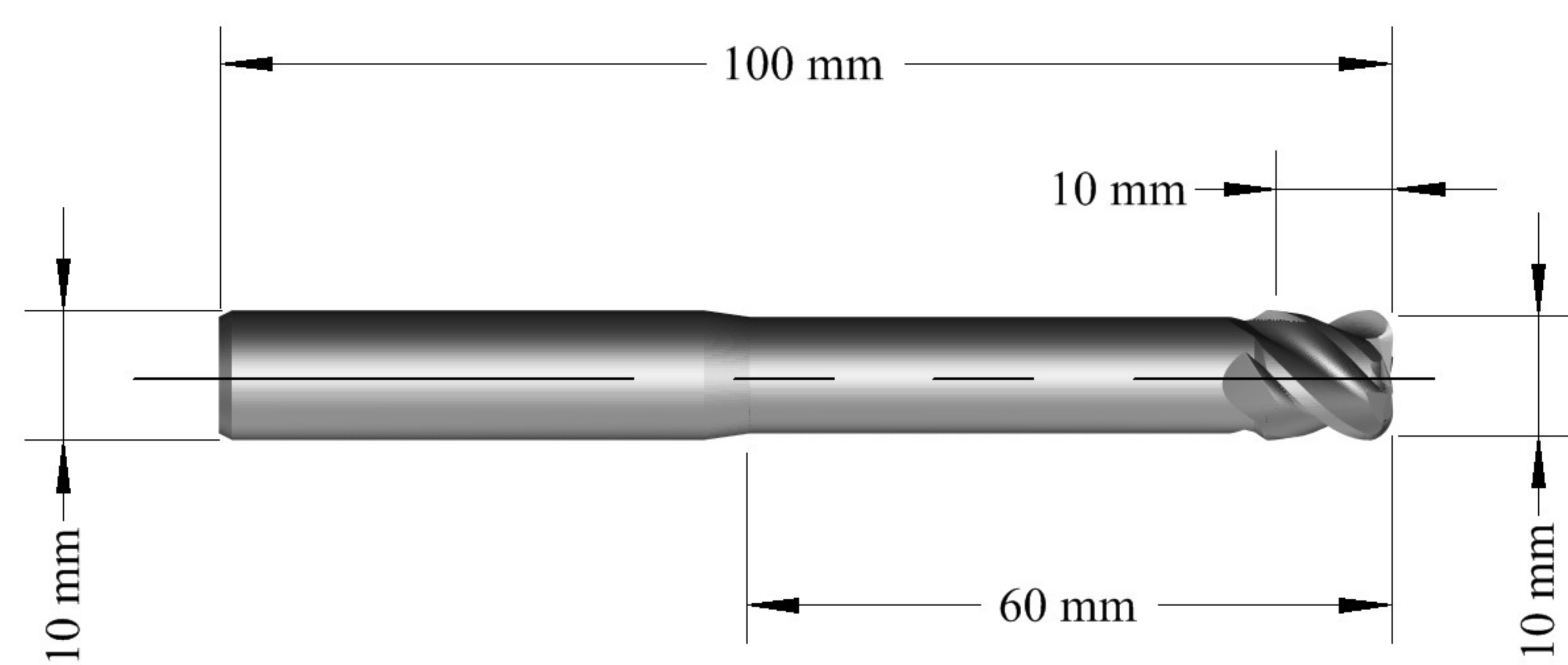
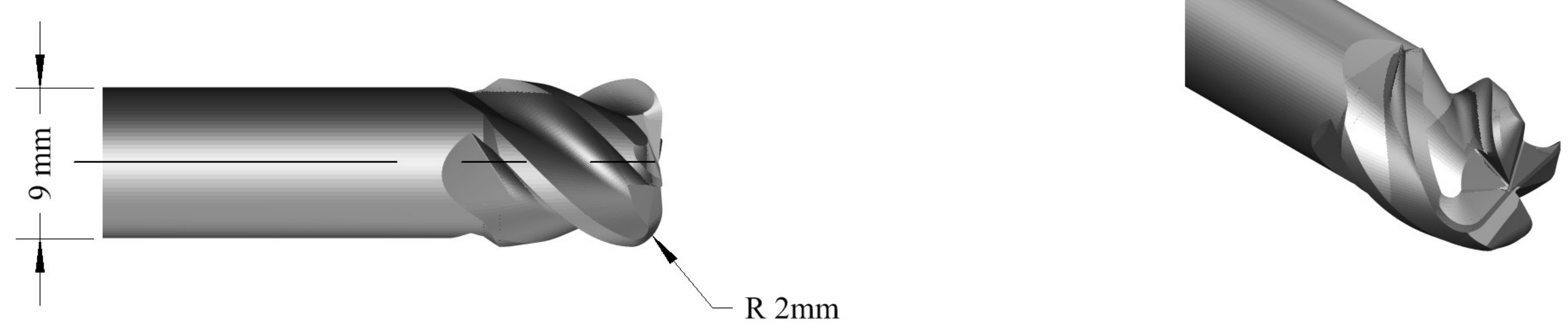

<b>QUICKVEND</b>	
QuickVend Location	
Quickgrind Stock	
QuickVend Stock	

**! IF IN DOUBT ASK !**

			
		<b>Customer Drawing 10mm HXLL Bulldog</b>	
Unit 5701 Shannon Place. Shannon Way. Tewkesbury Gloucestershire GL20 8SL Tel +44 (0)1684 294090 Fax +44 (0)1684 293168		PROPRIETARY DOCUMENT <small>This document is not to be copied or reproduced in whole or in part or communicated to third parties without the written consent of Quickgrind Ltd</small>	
DATE: 10/05/2013	SIZE <b>A4</b>	SPECIAL ID <b>10 HXLL</b>	QUICKGRIND PART NO <b>CE4D10x10-60R2FI1A2B</b>
DRAWN : QuickLAB Dept	SCALE 1 : 1	MATERIAL : Carbide	COATING <b>MX</b>
CUSTOMER :			REV <b>1</b>

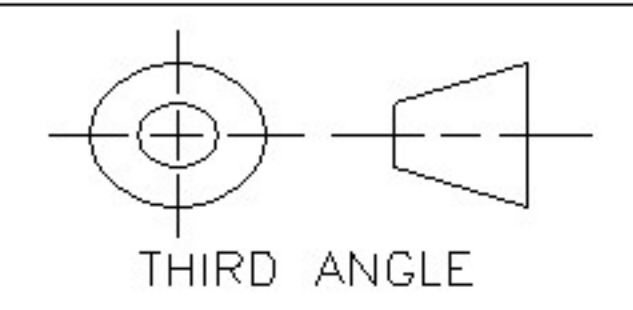

BLANK  
CMD10L100