

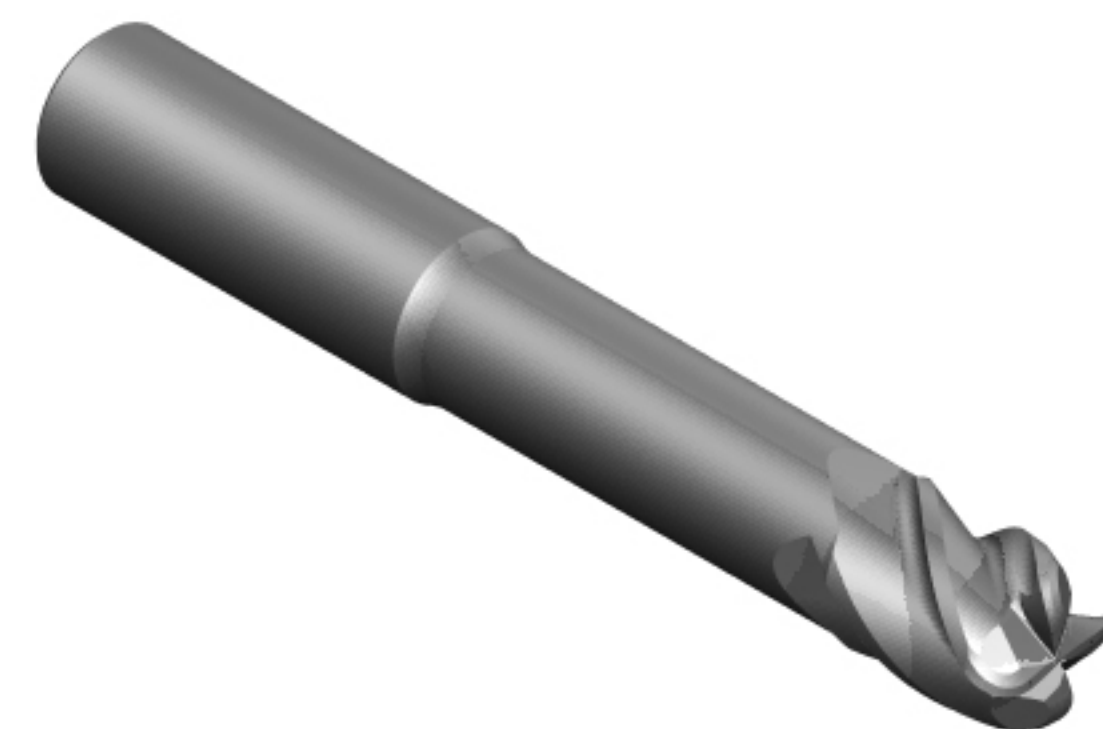

TOOL GEOMETRY DATA		
D	Diameter (End)	12 mm
Ds	Diameter (Shank)	12 mm
L	Length Of Cutting Edge.	15 mm
Ls	Length to Shank.	50 mm
Dn	Shank Neck Diameter.	11 mm
Lo	Overall Length.(Blank)	84 mm
T	Taper Angle (OD).	
R	Corner Radius	3 mm
N	Number Of Flutes.	4
P	Primary Relief (OD).	
Rd	Raised Depth (OD).	
Rw	Raised Land (OD).	
Sw	Secondary Land Width.	
F	Flute Depth	
Ra	Flute Rake. (Hook)	
Ty	Relief style.	
Pe	Primary Relief (End).	
Pl	Primary Land (End).	
Se	Secondary Relief (End).	
Da	Dish Angle (End).	
Ax	Axial Gash Angle.	
h	Gash Pad Width.	
H	Over Centre Length.	
Y	Gash Web Thickness.	
Hx	Helix Angle	
Ga	Gash Angle (L/S)	
Ro	Permissable Runout.	
Rl	Raised Land Length	

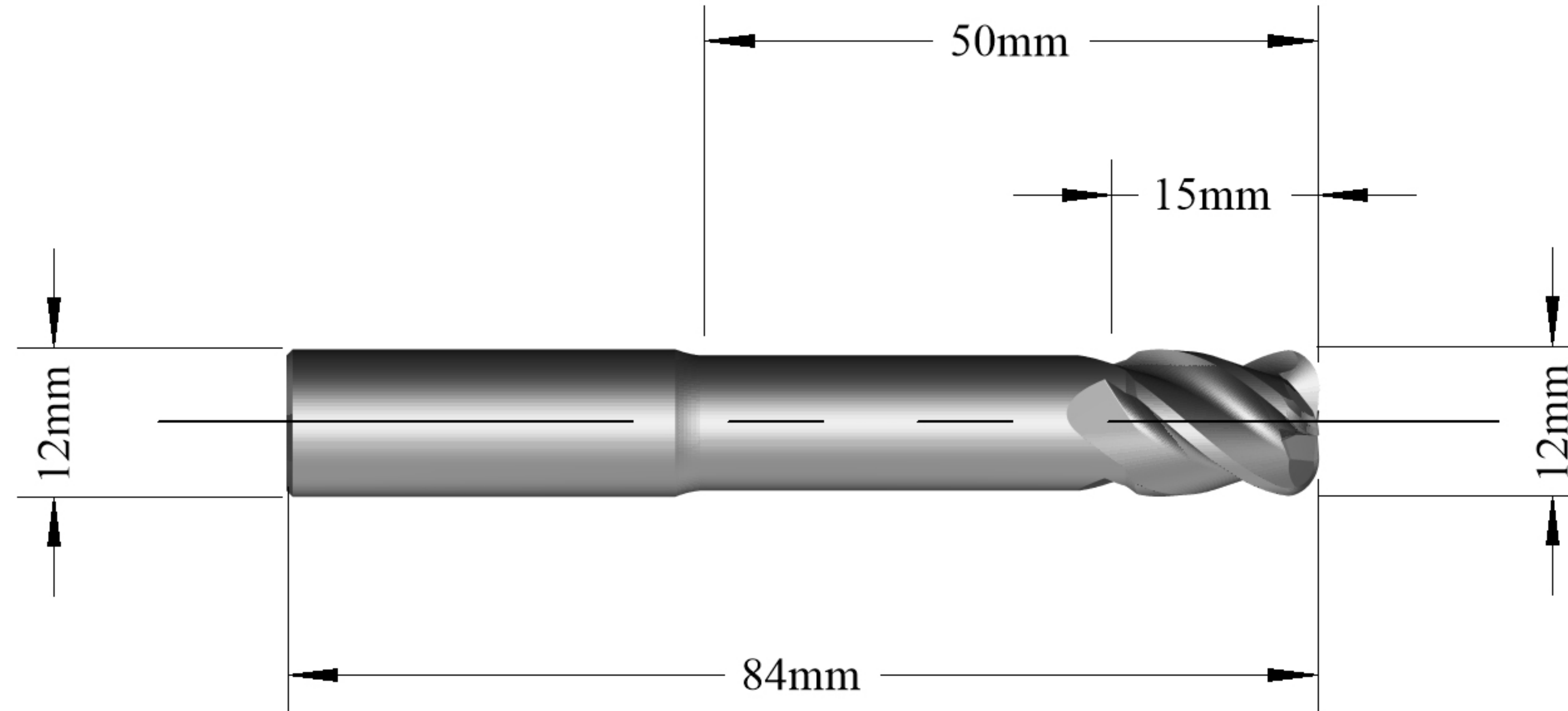
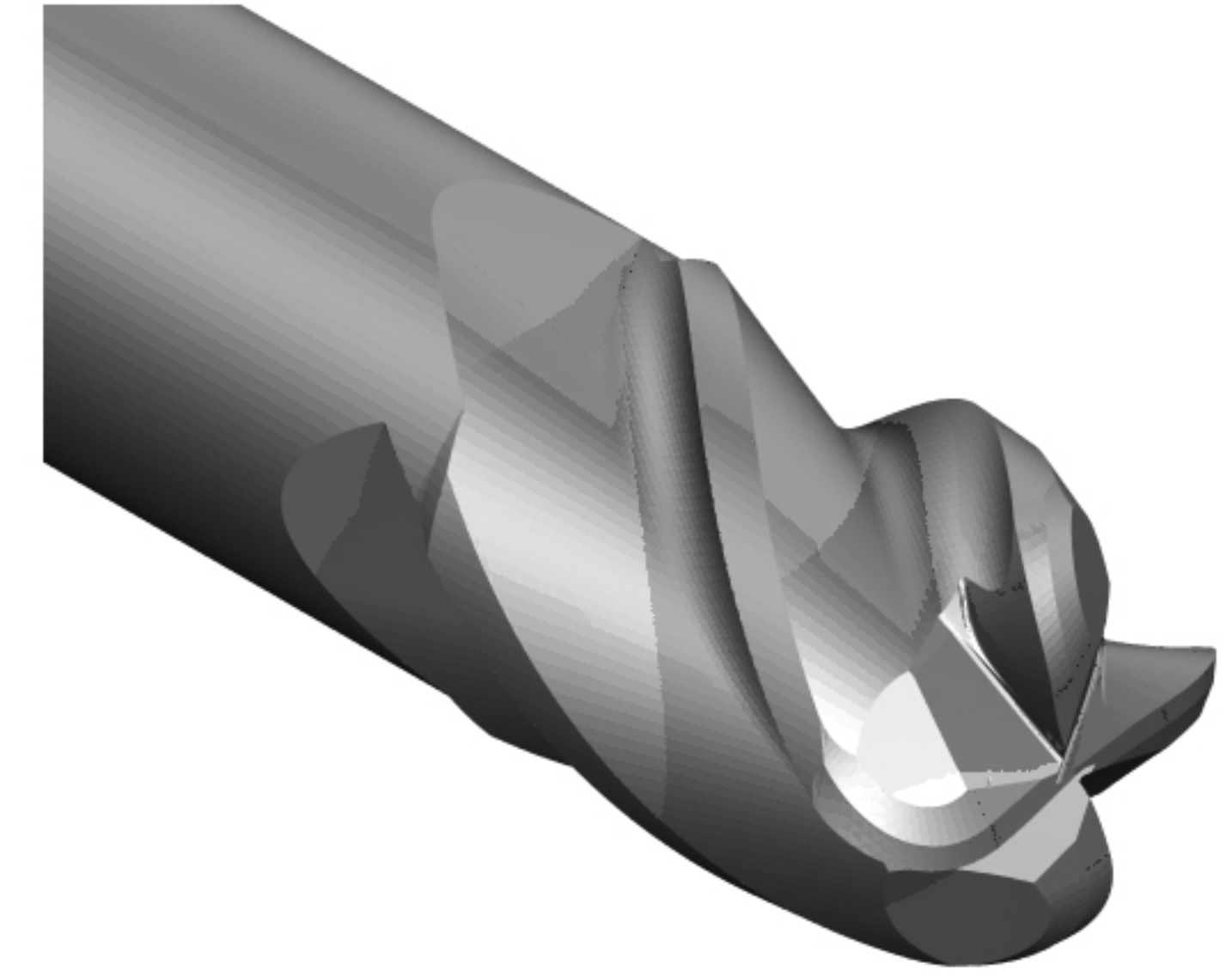
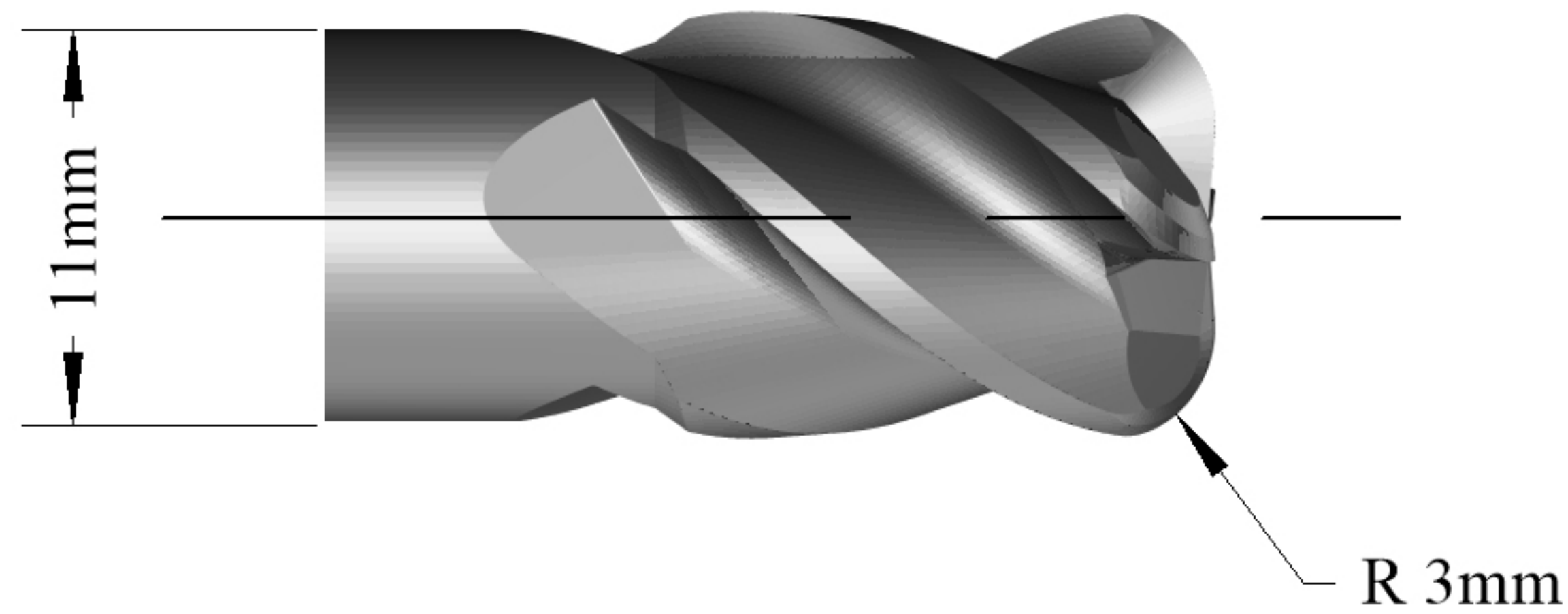
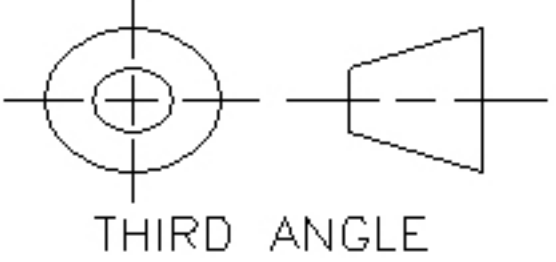

! IF IN DOUBT ASK !

Unit 5701 Shannon Place. Shannon Way. Tewkesbury Gloucestershire GL20 8SL Tel +44 (0)1684 294090 Fax +44 (0)1684 293168					
		TITLE Customer Drawing Bulldog 12 HX			
DATE: 28/05/2014 DRAWN : QuickLab Dept		PROPRIETARY DOCUMENT <small>This document is not to be copied or reproduced in whole or in part or communicated to third parties without the written consent of Quickgrind Ltd</small>			
		THIRD ANGLE 			
CUSTOMER :		SIZE A4	SPECIAL ID 12HX	QUICKGRIND PART NO CE4D12x15-50R3GG1A2B	REV 2
		SCALE 1 : 1	MATERIAL : Carbide	COATING MX	BLANK CMD12L84