

TOOL GEOMETRY DATA		
D	Diameter (End)	16 mm
Ds	Diameter (Shank)	16 mm
L	Length Of Cutting Edge.	15 mm
Ls	Length to Shank.	115 mm
Dn	Shank Neck Diameter.	15 mm
Lo	Overall Length.(Blank)	165 mm
T	Taper Angle (OD).	
R	Corner Radius	3.5 mm
N	Number Of Flutes.	4
P	Primary Relief (OD).	
Rd	Raised Depth (OD).	
Rw	Raised Land (OD).	
Sw	Secondary Land Width.	
F	Flute Depth	
Ra	Flute Rake. (Hook)	
Ty	Relief style.	
Pe	Primary Relief (End).	
Pl	Primary Land (End).	
Se	Secondary Relief (End).	
Da	Dish Angle (End).	
Ax	Axial Gash Angle.	
h	Gash Pad Width.	
H	Over Centre Length.	
Y	Gash Web Thickness.	
Hx	Helix Angle	
Ga	Gash Angle (L/S)	
Ro	Permissable Runout.	
Rl	Raised Land Length	

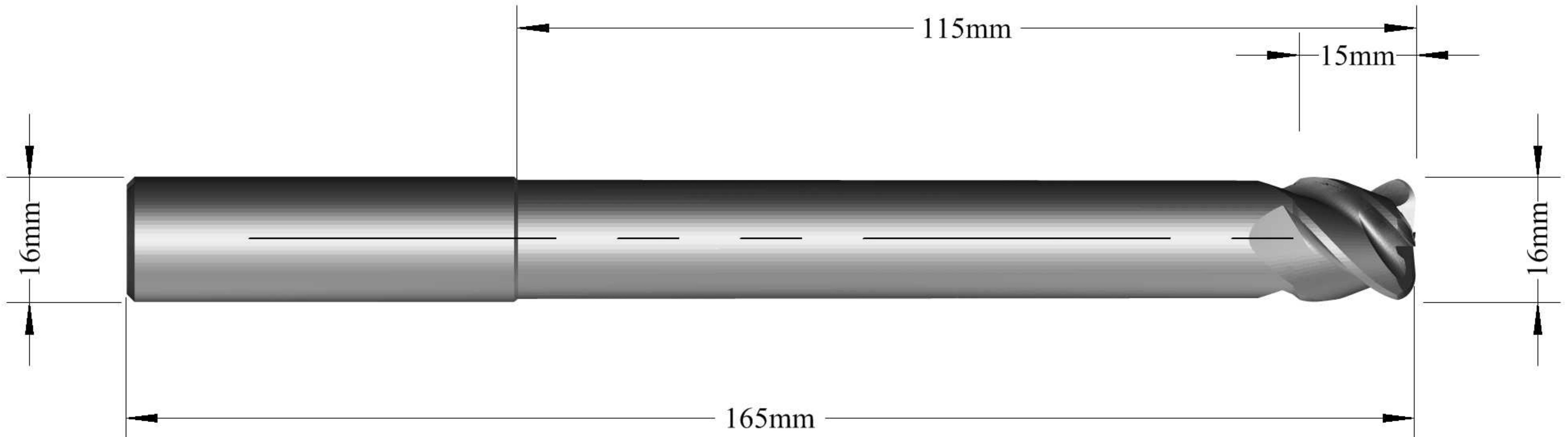
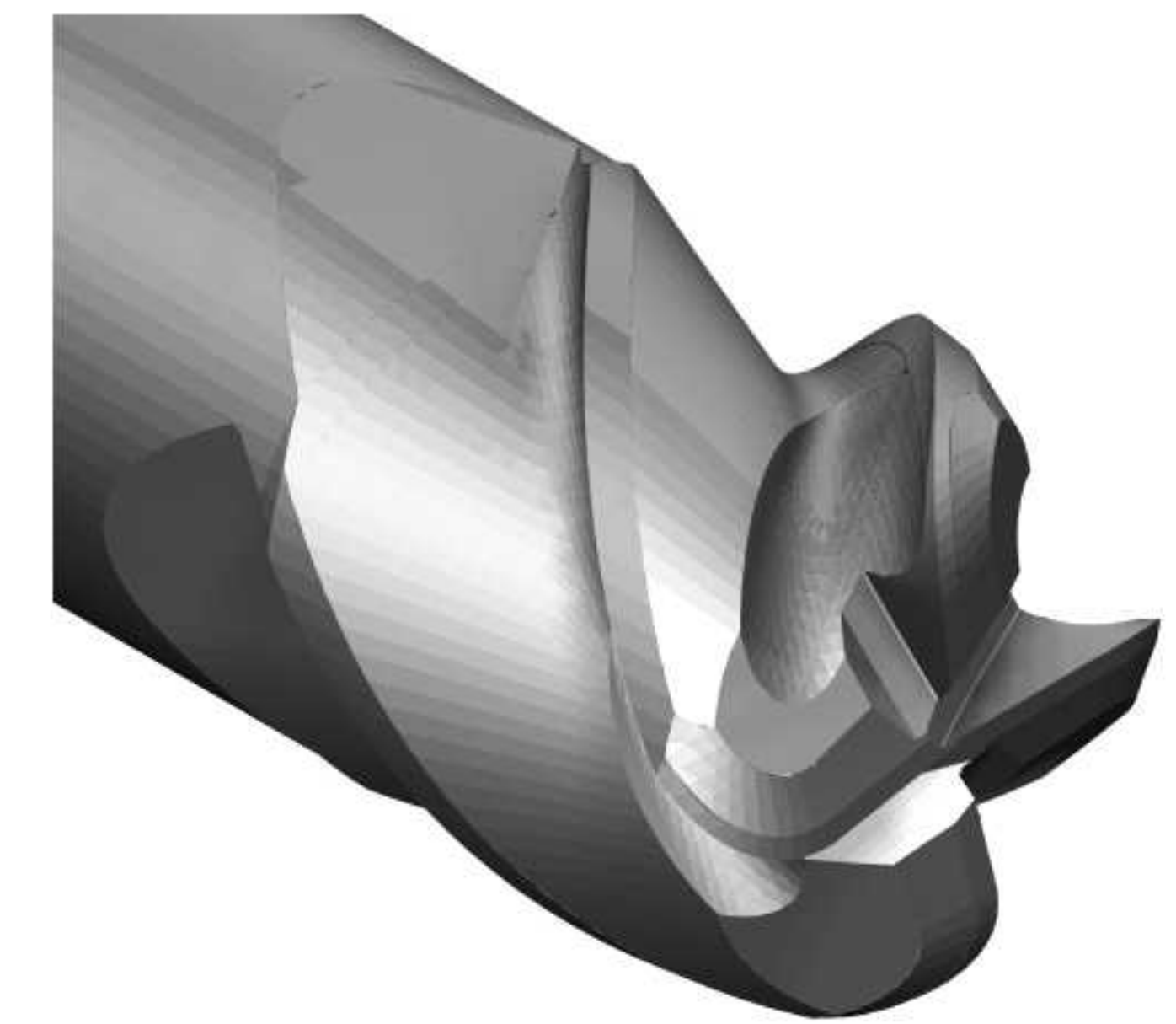
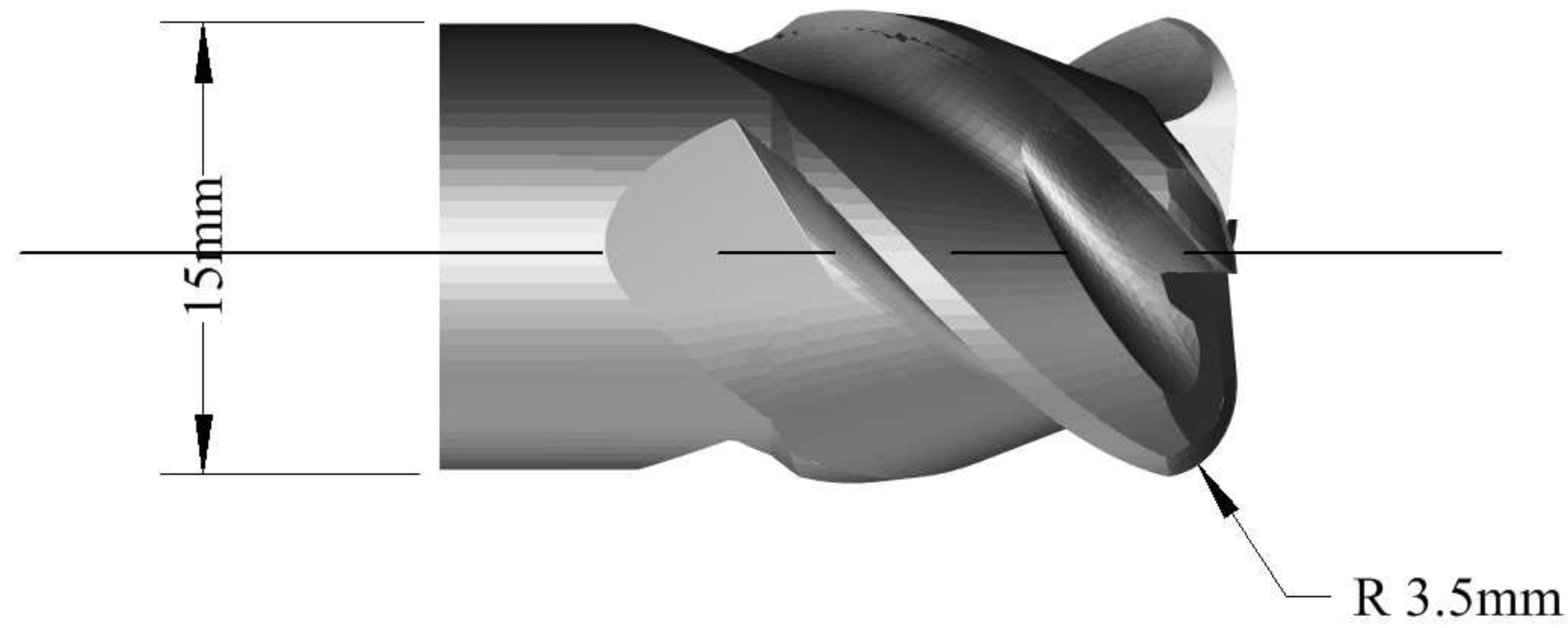

! IF IN DOUBT ASK !

QuickVend Location	
Quickgrind Stock	
QuickVend Stock	

		TITLE Customer Drawing Bulldog 16 HXLLL	
Unit 5701 Shannon Place, Shannon Way, Tewkesbury Gloucestershire GL20 8SL Tel +44 (0)1684 294090 Fax +44 (0)1684 293168		PROPRIETARY DOCUMENT <small>This document is not to be copied or reproduced in whole or in part or communicated to third parties without the written consent of Quickgrind Ltd</small>	
		BLANK CMD16L165	
DATE: 04/04/2011	SIZE A4	SPECIAL ID 16HXLLL	QUICKGRIND PART NO CE4D16x15-115R3.5JO1A2B
DRAWN : QuickLab Dept	SCALE 1 : 1	MATERIAL : Carbide	COATING MX
CUSTOMER :			REV 1

