

IF IN DOUBT PLEASE ASK

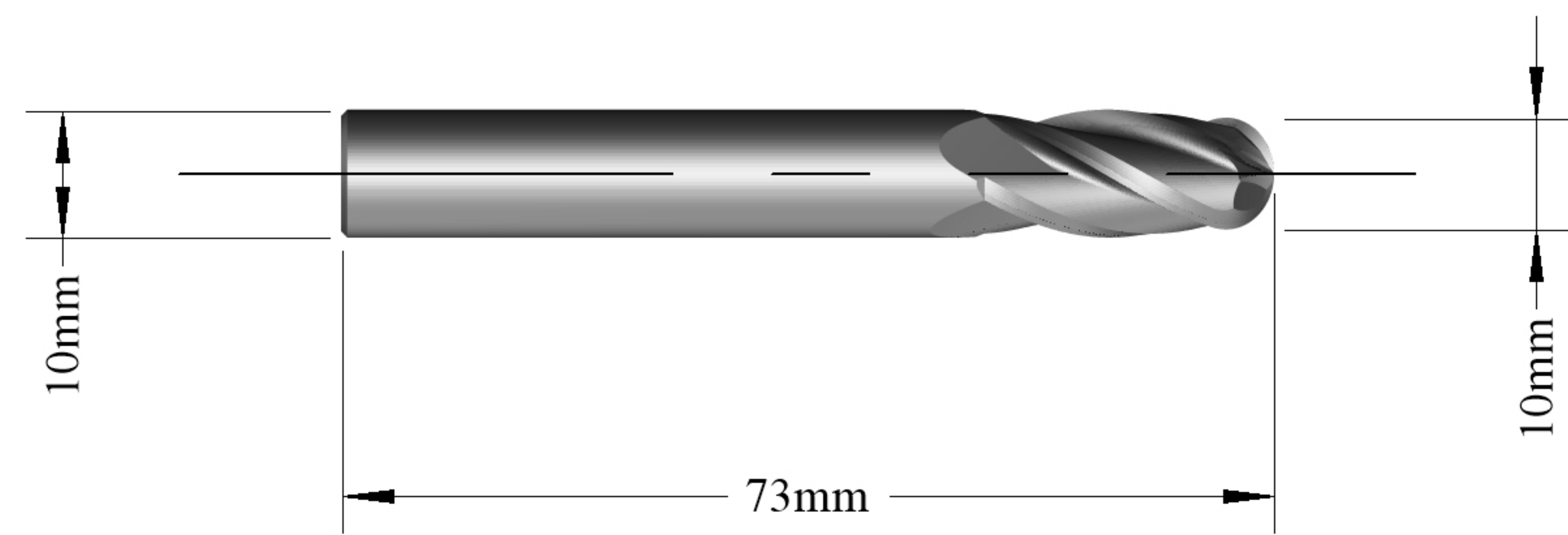

D	Diameter (End)	10mm
Ds	Diameter (Shank)	10mm
L	Length Of Cutting Edge	22mm
Ls	Length to Shank	
Dn	Shank Neck Diameter	
Lo	Overall Length (Blank)	73mm
T	Taper Angle (OD)	
R	Corner Radius	5mm
N	Number Of Flutes	4
P	Primary Relief (OD)	
Rd	Raised Depth (OD)	
Rw	Raised Land (OD)	
Sw	Secondary Land Width	
F	Flute Depth	
Ra	Flute Rake (Hook)	
Ty	Relief style	
Pe	Primary Relief (End)	
Pl	Primary Land (End)	
Se	Secondary Relief (End)	
Da	Dish Angle (End)	
Ax	Axial Gash Angle	
h	Gash Pad Width	
H	Over Centre Length	
Y	Gash Web Thickness	
Hx	Helix Angle	
Ga	Gash Angle (L/S)	
Ro	Permissible Runout	
Rl	Raised Land Length	

STEP	
FEED	
RPM	
TOOL LIFE	

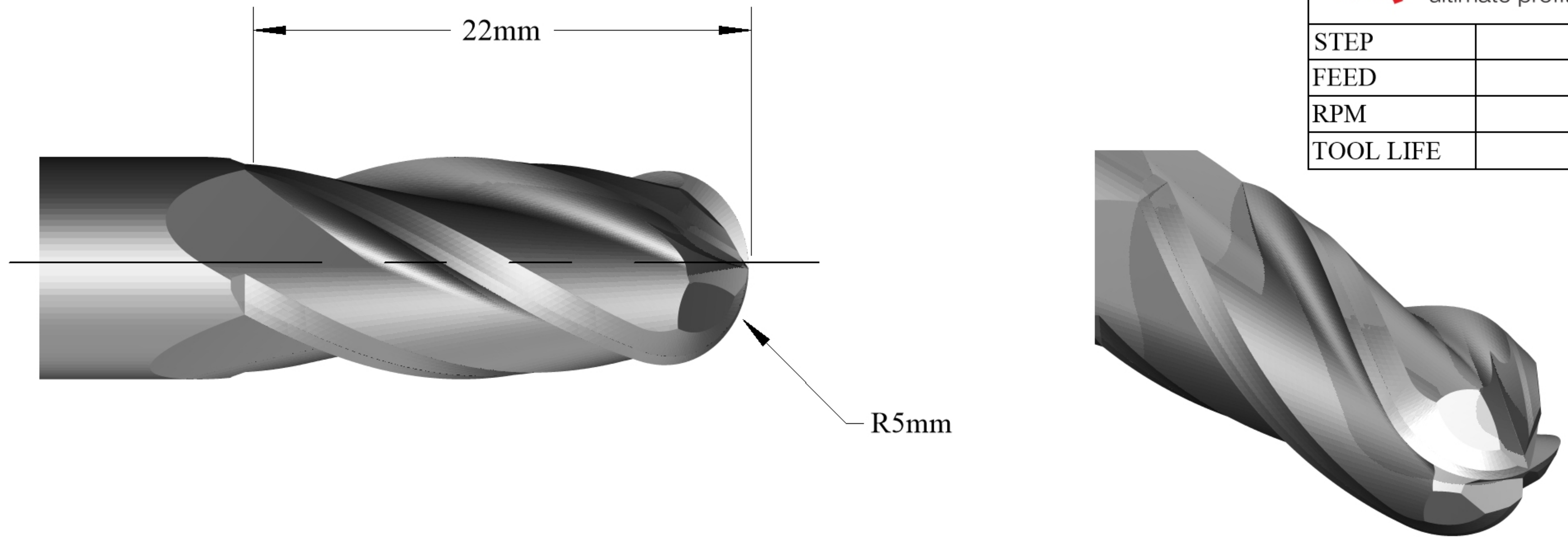

REV.	DESCRIPTION	DATE

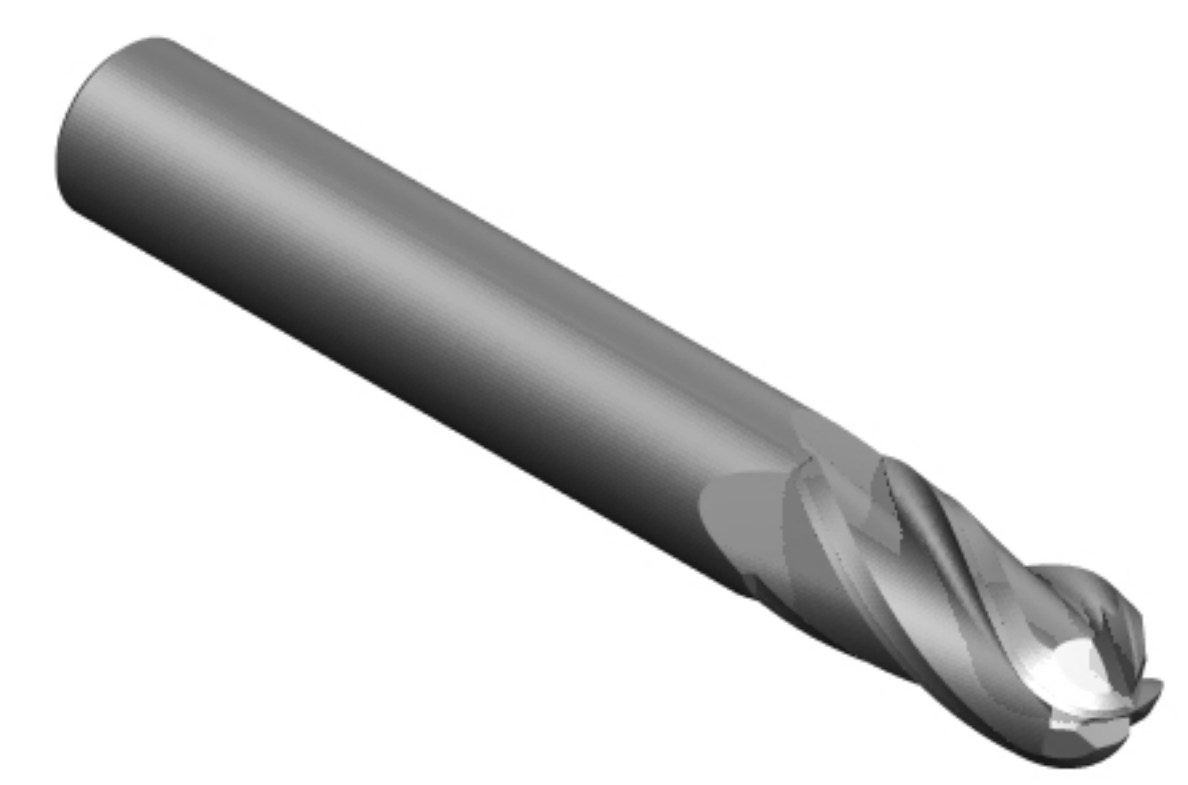

QuickVend Location	
Quickgrind Stock	
QuickVend Stock	

Unit 5701 Shannon Place, Shannon Way
Tewkesbury, Gloucestershire, GL20 8SL
T +44 (0)1684 294090 F +44 (0)1684 293168

Date: 27/10/22

Drawn: IV

Checked: KL

TITLE
Customer Drawing 4 Flute Carbide
10mm x 22mm R5mm QBall MX Coating

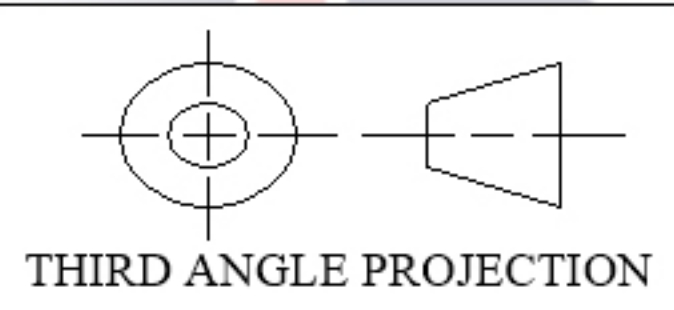

PROPRIETARY DOCUMENT
This document is not to be copied or reproduced in whole or in part or communicated to third parties without the prior written consent of Quickgrind Ltd

BLANK
CMD10L73

Customer: Quickgrind Customer Approval: Brian Pearce Date: 2/11/22

SIZE A4	SPECIAL I.D 336100	QUICKGRIND PART NUMBER CB4D10x22F5FE1A2B	REV 1
------------	-----------------------	---	----------

CUSTOMER APPROVAL: Please check all drawing details, signing this document will signify customer acceptance and will be final. Signatory confirms that they are authorised to sign such documents on behalf of the company.

SCALE: 1 : 1 MATERIAL: Carbide COATING: MX

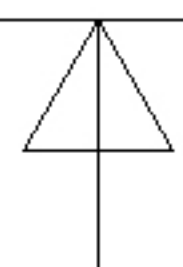

IF IN DOUBT PLEASE ASK