

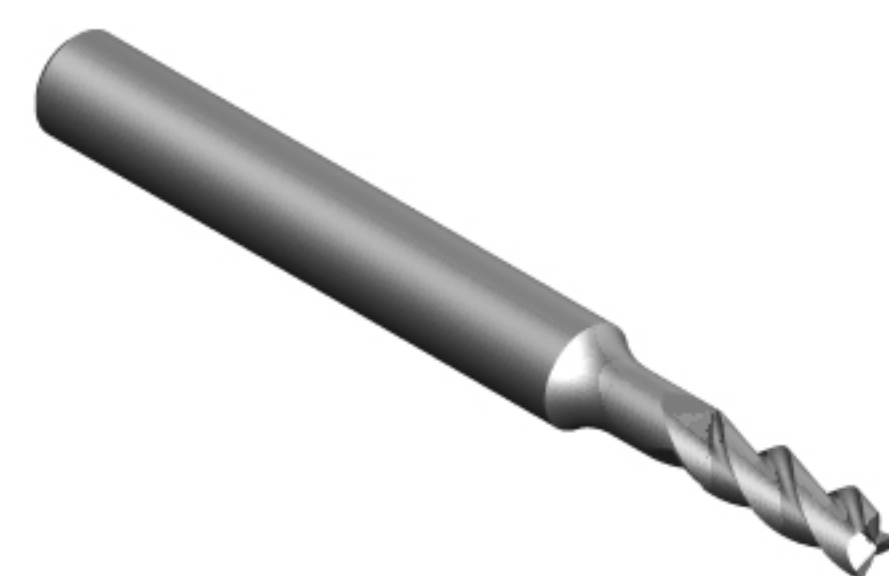

D	Diameter (End)	4mm
Ds	Diameter (Shank)	6mm
L	Length Of Cutting Edge	11mm
Ls	Length to Shank	18mm
Dn	Shank Neck Diameter	3.8mm
Lo	Overall Length (Blank)	58mm
T	Taper Angle (OD)	
R	Corner Chamfer	0.06mm
N	Number Of Flutes	3
P	Primary Relief (OD)	
Rd	Raised Depth (OD)	
Rw	Raised Land (OD)	
Sw	Secondary Land Width	
F	Flute Depth	
Ra	Flute Rake (Hook)	
Ty	Relief style	
Pe	Primary Relief (End)	
Pl	Primary Land (End)	
Se	Secondary Relief (End)	
Da	Dish Angle (End)	
Ax	Axial Gash Angle	
h	Gash Pad Width	
H	Over Centre Length	
Y	Gash Web Thickness	
Hx	Helix Angle	
Ga	Gash Angle (L/S)	
Ro	Permissible Runout	
Rl	Raised Land Length	

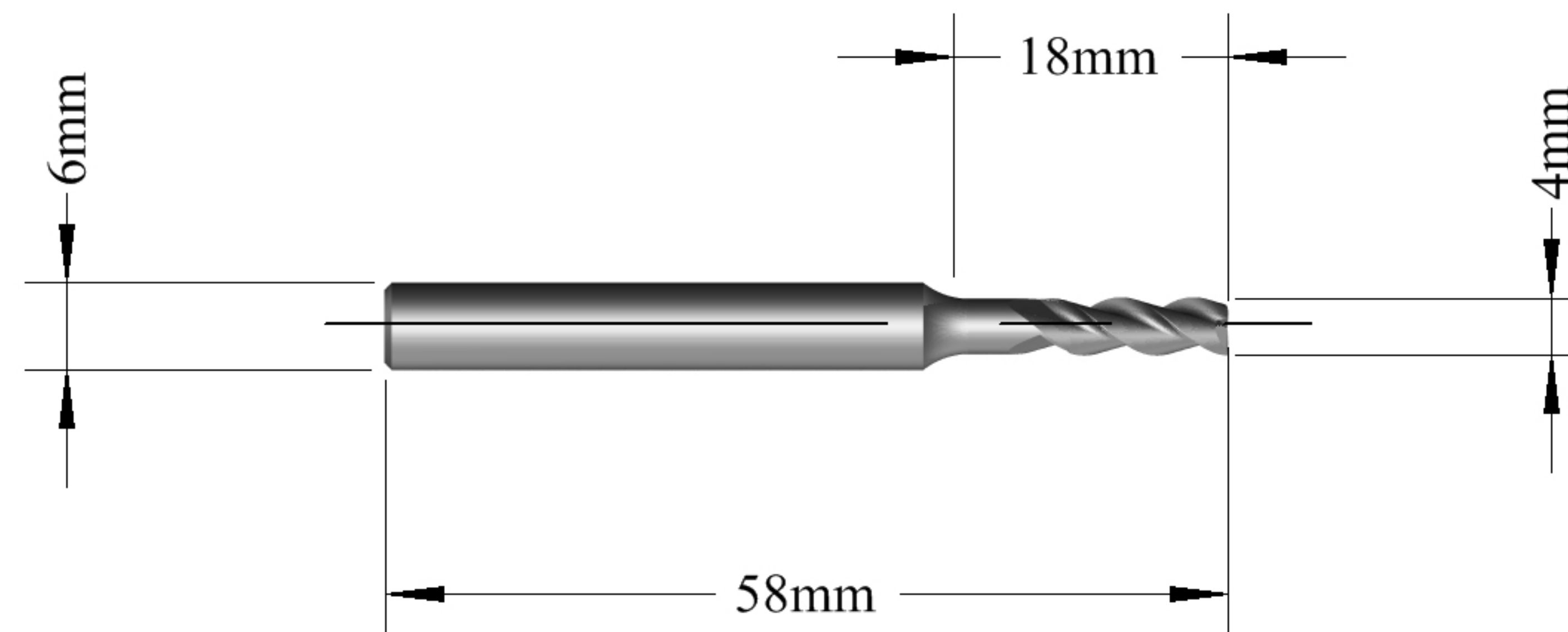

STEP	
FEED	
RPM	
TOOL LIFE	

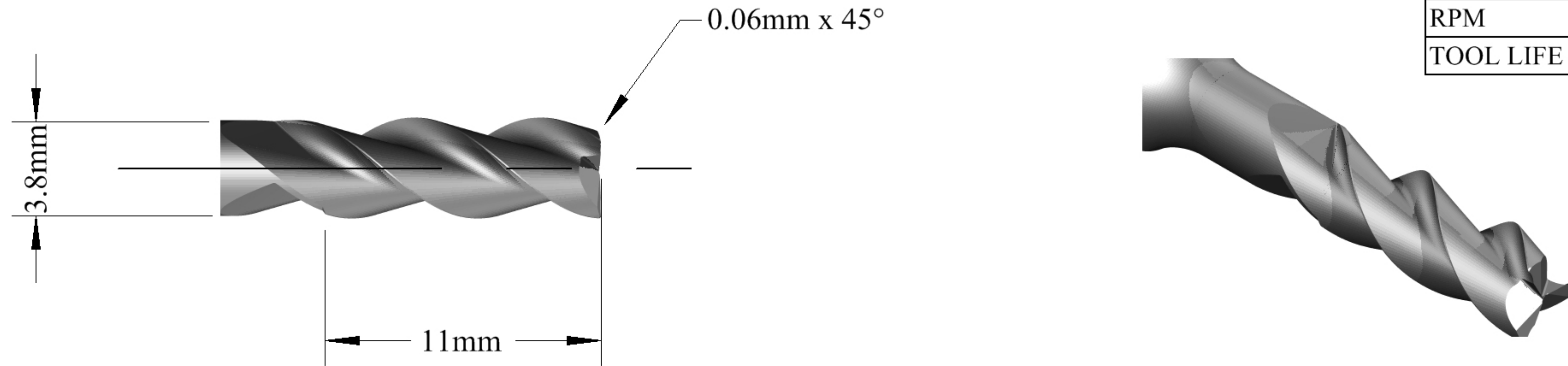

REV.	DESCRIPTION	DATE



TITLE Customer Drawing 3 flute carbide Endmill 4mm dia Uncoated

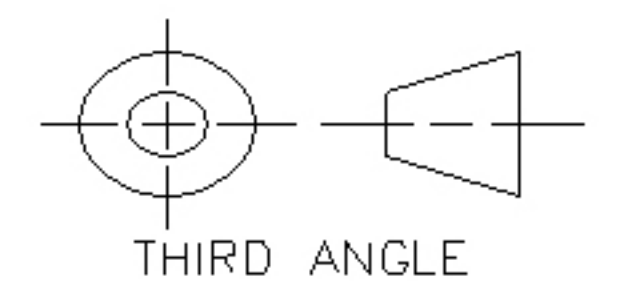

Unit 5701 Shannon Place, Shannon Way,
Tewkesbury Gloucestershire GL20 8SL
Tel +44 (0)1684 294090 Fax +44 (0)1684 293168

PROPRIETARY DOCUMENT
This document is not to be copied or reproduced in whole or in part or communicated to third parties without the written consent of Quickgrind Ltd

BLANK
CMD6L58

Date: 6/1/17

SIZE A4	SPECIAL ID 398408	QUICKGRIND PART NO CE3A4x11-18C0.06DB1A2A	REV 1
-------------------	----------------------	--	----------

Drawn: RS

SCALE: 1 : 1 MATERIAL: Carbide COATING: Uncoated

Checked: RH

QuickVend Location

Quickgrind Stock

QuickVend Stock

Customer: N/A

Customer Approval: Mike Stobart

Date: 6/1/17

CUSTOMER APPROVAL: Please check all drawing details, signing this document will signify customer acceptance and will be final. Signatory confirms that they are authorised to sign such documents on behalf of the company.

IF IN DOUBT PLEASE ASK