

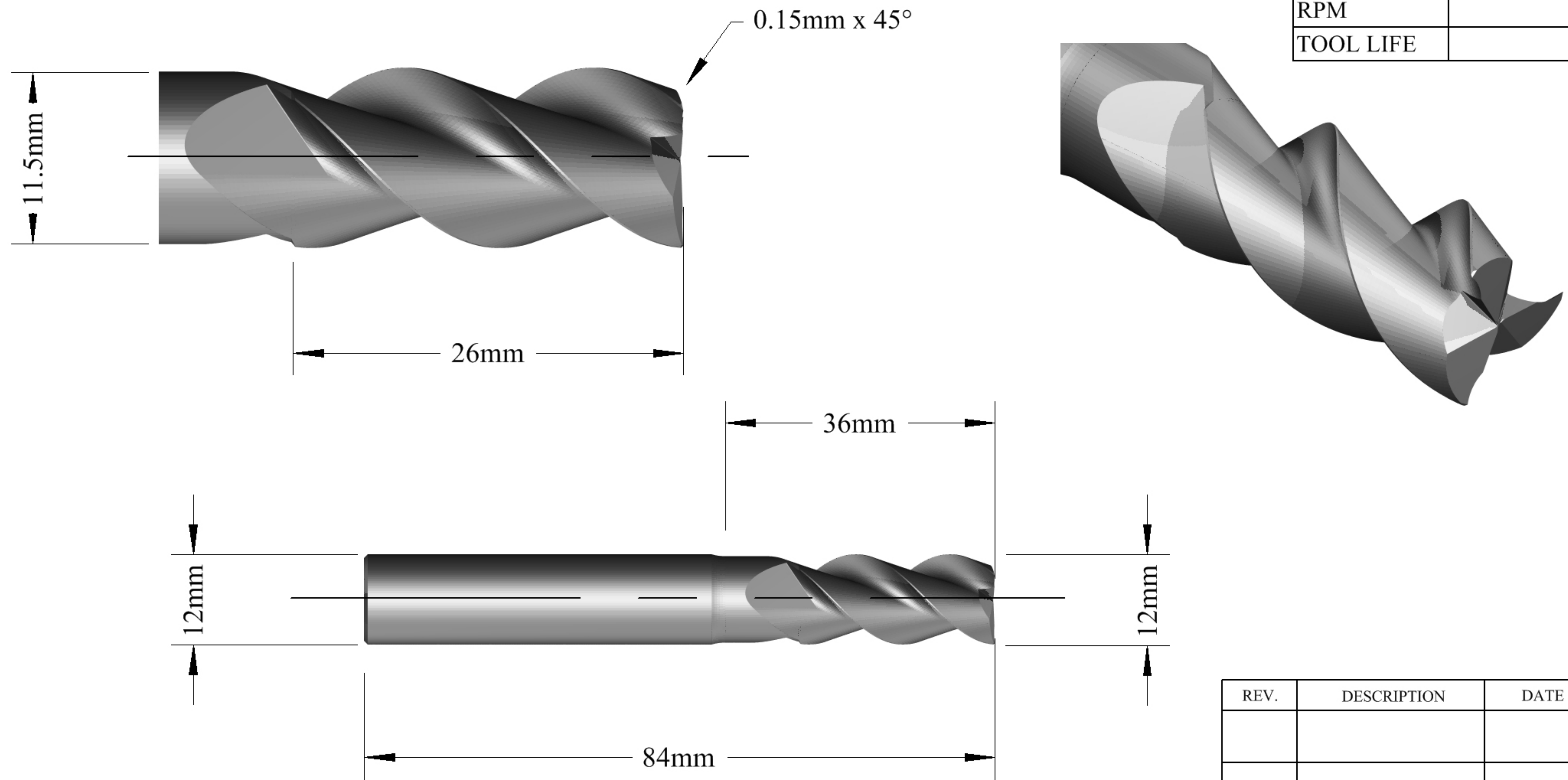

D	Diameter (End)	12mm
Ds	Diameter (Shank)	12mm
L	Length Of Cutting Edge	26mm
Ls	Length to Shank	36mm
Dn	Shank Neck Diameter	11.5mm
Lo	Overall Length (Blank)	84mm
T	Taper Angle (OD)	
R	Corner Chamfer	0.15mm
N	Number Of Flutes	3
P	Primary Relief (OD)	
Rd	Raised Depth (OD)	
Rw	Raised Land (OD)	
Sw	Secondary Land Width	
F	Flute Depth	
Ra	Flute Rake (Hook)	
Ty	Relief style	
Pe	Primary Relief (End)	
Pl	Primary Land (End)	
Se	Secondary Relief (End)	
Da	Dish Angle (End)	
Ax	Axial Gash Angle	
h	Gash Pad Width	
H	Over Centre Length	
Y	Gash Web Thickness	
Hx	Helix Angle	
Ga	Gash Angle (L/S)	
Ro	Permissible Runout	
Rl	Raised Land Length	



STEP	
FEED	
RPM	
TOOL LIFE	



REV.	DESCRIPTION	DATE

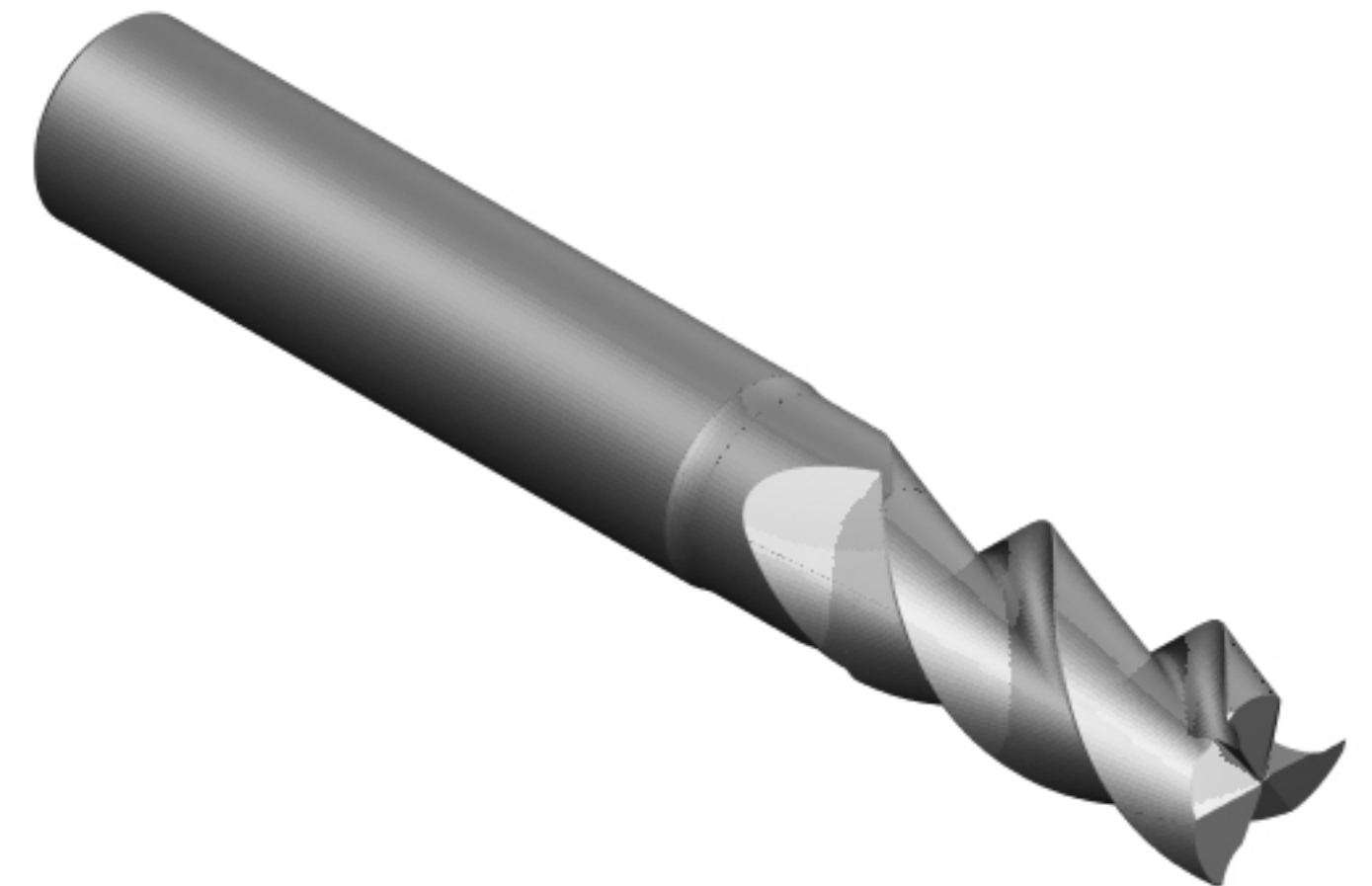

Unit 5701 Shannon Place, Shannon Way,
Tewkesbury Gloucestershire GL20 8SL
Tel +44 (0)1684 294090 Fax +44 (0)1684 293168



TITLE Customer Drawing 3 flute carbide Endmill 12mm dia Uncoated

THIRD ANGLE

PROPRIETARY DOCUMENT
This document is not to be copied or reproduced in whole or in part or communicated to third parties without the written consent of Quickgrind Ltd

BLANK
CMD12L84

Date: 6/1/17
Drawn: RS

SIZE	SPECIAL ID	QUICKGRIND PART NO	REV
A4	398435	CE3A12x26-36C0.15GG1A2A	1

Checked: RH

SCALE: 1 : 1

MATERIAL: Carbide

COATING: Uncoated

QUICKVEND	
QuickVend Location	
Quickgrind Stock	
QuickVend Stock	
Customer: N/A	Customer Approval: Mike Stobart
	Date: 6/1/17

CUSTOMER APPROVAL: Please check all drawing details, signing this document will signify customer acceptance and will be final. Signatory confirms that they are authorised to sign such documents on behalf of the company.

IF IN DOUBT PLEASE ASK