

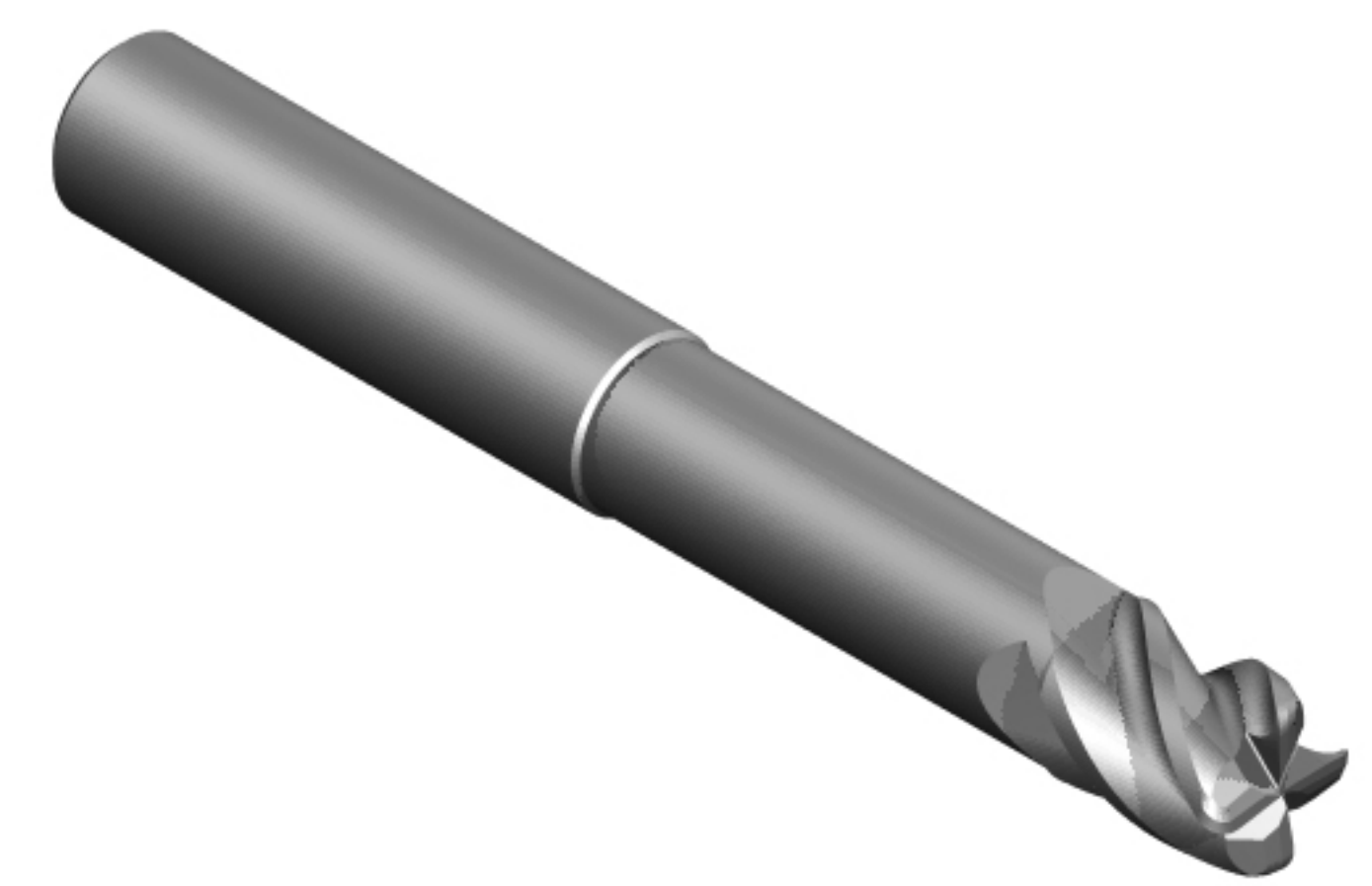

TOOL GEOMETRY DATA

D	Diameter (End)	8 mm
Ds	Diameter (Shank)	8 mm
L	Length Of Cutting Edge.	10 mm
Ls	Length to Shank.	35 mm
Dn	Shank Neck Diameter.	7.5 mm
Lo	Overall Length.(Blank)	64 mm
T	Taper Angle (OD).	
R	Corner Radius	1 mm
N	Number Of Flutes.	4
P	Primary Relief (OD).	
Rd	Raised Depth (OD).	
Rw	Raised Land (OD).	
Sw	Secondary Land Width.	
F	Flute Depth	
Ra	Flute Rake. (Hook)	
Ty	Relief style.	
Pe	Primary Relief (End).	
Pl	Primary Land (End).	
Se	Secondary Relief (End).	
Da	Dish Angle (End).	
Ax	Axial Gash Angle.	
h	Gash Pad Width.	
H	Over Centre Length.	
Y	Gash Web Thickness.	
Hx	Helix Angle	
Ga	Gash Angle (L/S)	
Ro	Permissable Runout.	
Rl	Raised Land Length	

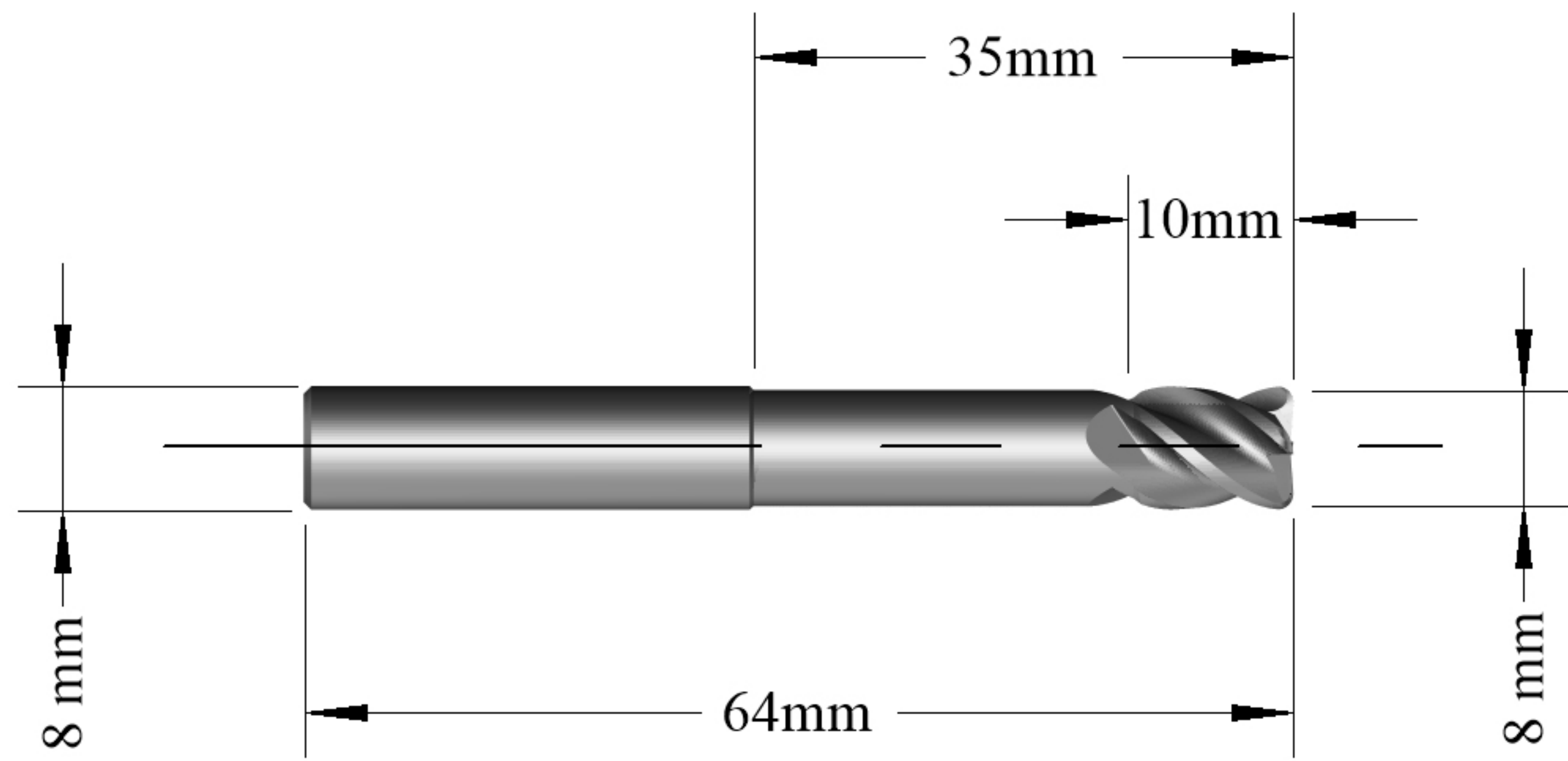
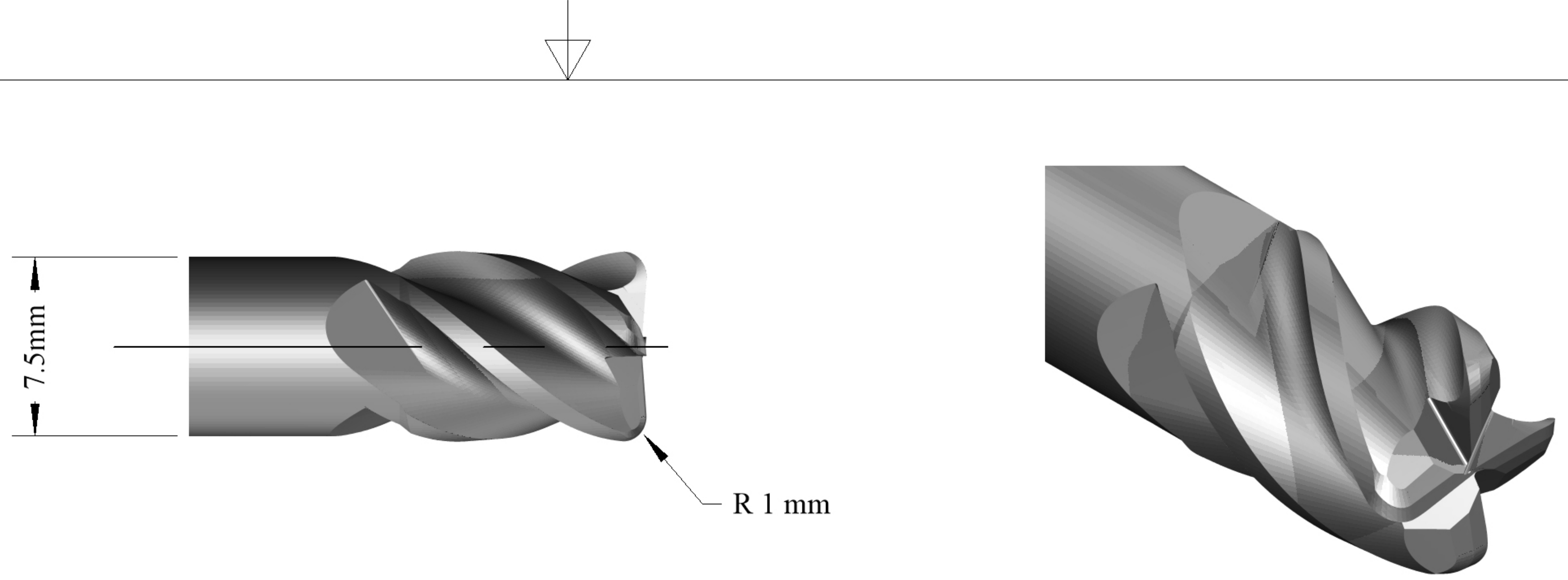

QUICKVEND	
QuickVend Location	
Quickgrind Stock	
QuickVend Stock	

! IF IN DOUBT ASK !



Unit 5701 Shannon Place. Shannon Way.
Tewkesbury Gloucestershire GL20 8SL
Tel +44 (0)1684 294090 Fax +44 (0)1684 293168

DATE: 14/9/15
DRAWN : QuickLAB Dept
CUSTOMER :



Customer Drawing 8HX Bulldog

THIRD ANGLE

PROPRIETARY DOCUMENT
This document is not to be copied or reproduced in whole or in part or communicated to third parties without the written consent of Quickgrind Ltd

BLANK
CMD8L64

SIZE A4	SPECIAL ID 8HX	QUICKGRIND PART NO CE4D8x10-35R1EC1A2B	REV 3
SCALE 1 : 1	MATERIAL : Carbide	COATING MX	